

USB TO SPI AND UART

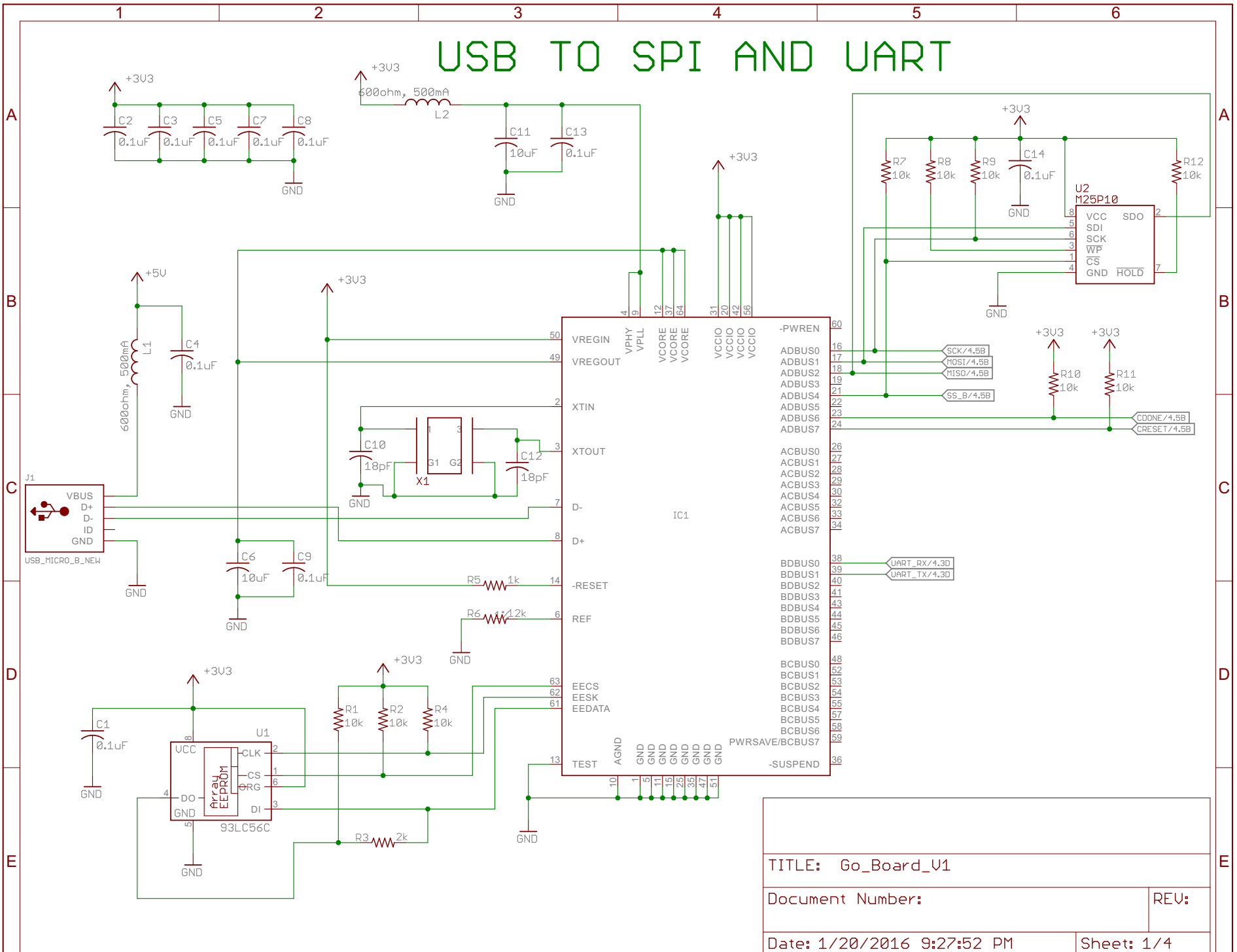

TITLE: Go_Board_V1

Document Number:

REV:

Date: 1/20/2016 9:27:52 PM

Sheet: 1/4

LEDs, SWITCHES, CONNECTORS

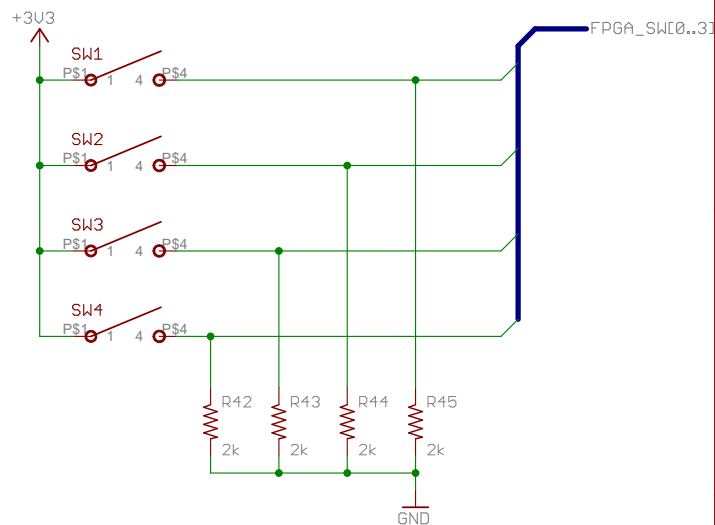
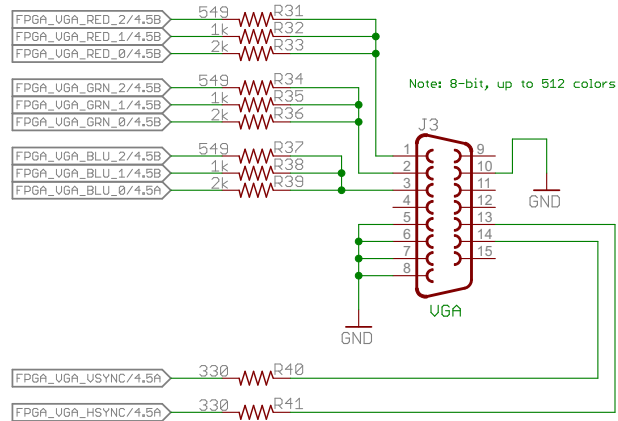
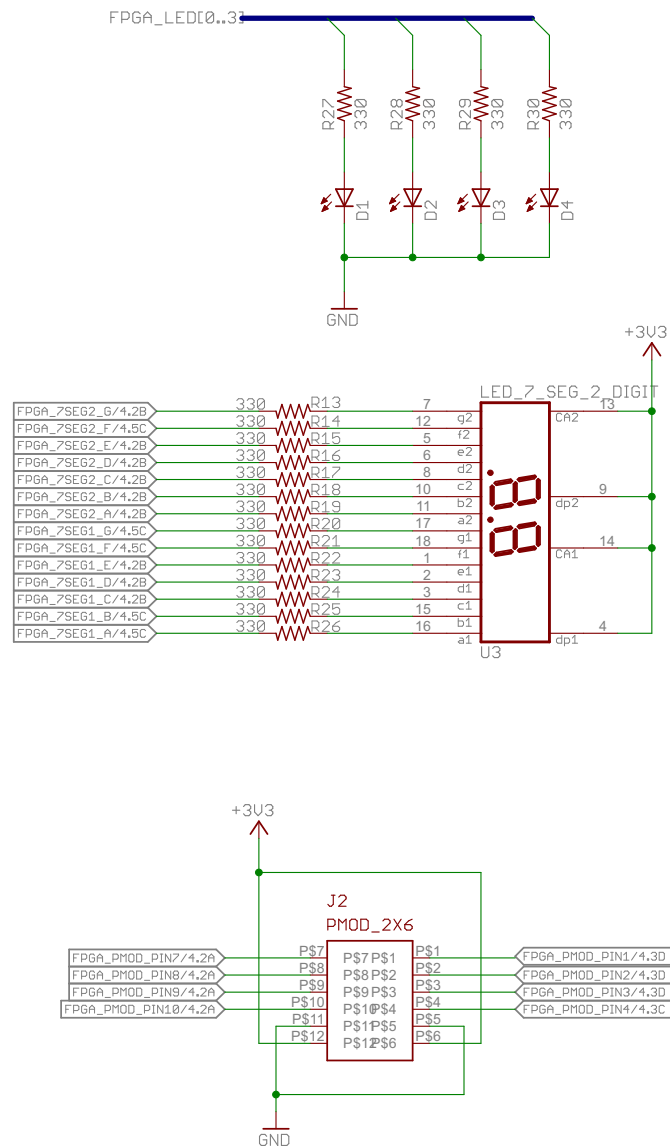

TITLE: Go_Board_V1	
Document Number:	REV:
Date: 1/20/2016 9:27:52 PM	Sheet: 2/4

POWER SUPPLIES, CAPS

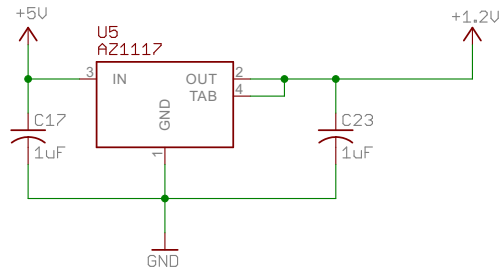
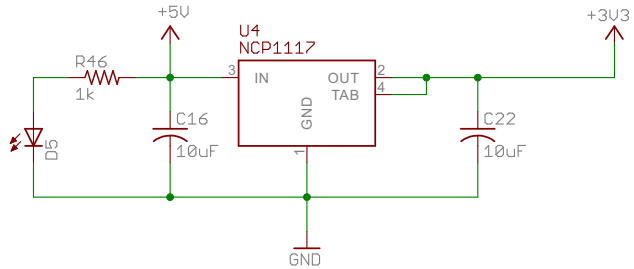
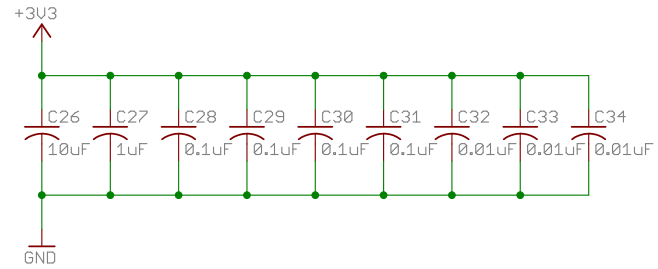
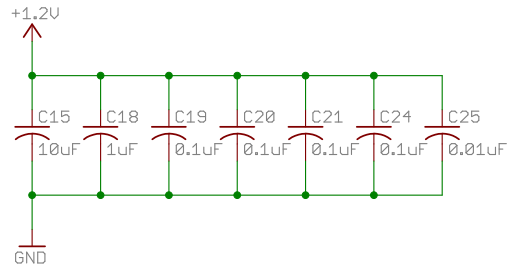

TITLE: Go_Board_V1

Document Number:

REV:

Date: 1/20/2016 9:27:52 PM

Sheet: 3/4

FPGA

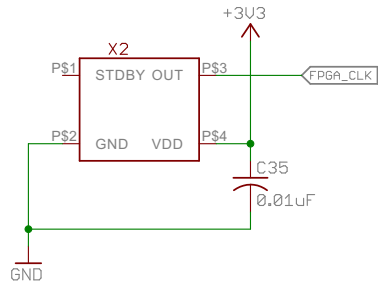
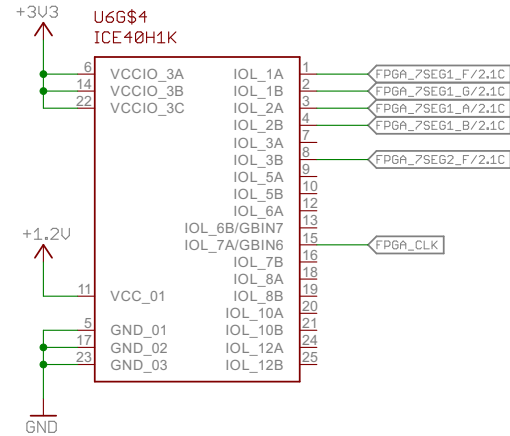
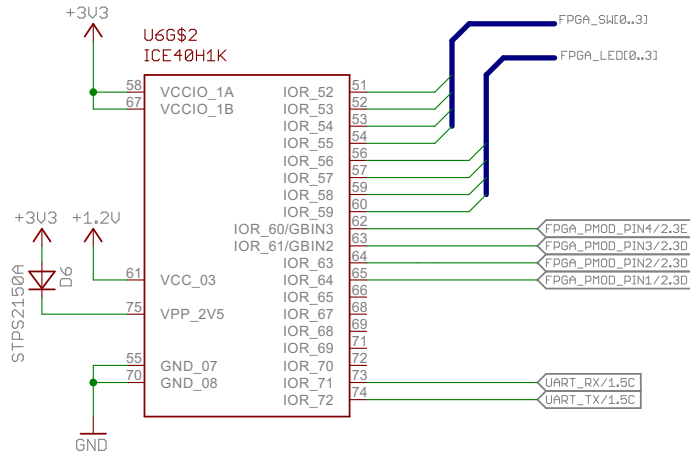
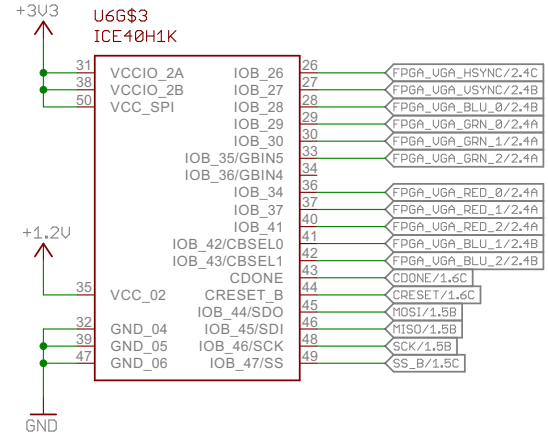
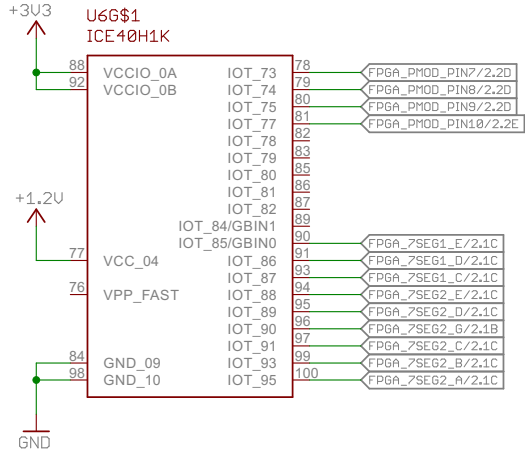

TITLE: Go_Board_V1

Document Number:

REV:

Date: 1/20/2016 9:27:52 PM

Sheet: 4/4